

**Chapter 10** To ensure greater efficiency for the building/system and the reduction of polluting emissions, the centralised heating system is once again becoming popular in the new condominiums. Each condominium, however, wants to manage ON/OFF times and comfort temperatures autonomously, paying only for what has actually been consumed. To meet these needs, we've produced a complete series of solutions for directly metering thermal energy. Together with individual thermoregulation, they allow you to combine the advantages of a centralised system with those of an autonomous one.

---



## Direct and indirect thermal energy metering

### *Products*

- 222 User modules for direct metering
- 226 Heat interface units for direct metering
- 233 Thermal energy meters, water meters, data centralization systems
- 238 Indirect metering (heat cost allocators)
- 240 Basic units and accessories  
(boxes, templates, insulations, other components)

## ➤ User modules for direct metering

### GE555

STANDARD

PRODUCT CODE	CONNECTIONS	DIMENSIONS (L X H X D) mm	BALANCING	UNITS FOR DOMESTIC WATER METERS	☐	☒
GE555Y461	3/4"	500 x 500 x 110±160	Only by-pass	2	1	-
GE555Y462	3/4"	600 x 600 x 110±160	Static	3	1	-
GE555Y463	1"	600 x 600 x 110±160	Static	3	1	-
GE555Y468	3/4"	600 x 600 x 110±160	Dynamic	3	1	-
GE555Y469	1"	600 x 600 x 110±160	Dynamic	3	1	-
GE555Y472	3/4"	600 x 600 x 145±195	Only by-pass - with double delivery	2	1	-



User module for centralized heating and/or cooling systems.

- Shut-off ball valves
- Motorizable zone valve
- Guide rails for installation of domestic and/or service water metering units
- Plastic spacer for installation of thermal energy meter
- Box with terminal board for electric connections
- Housing for thermal energy meter delivery temperature probe, built into the shut-off valve
- Painted sheet metal cabinet (RAL9010) with lockable door and adjustable frame depth
- Fittings for connection and fixing
- Max. working temperature 110 °C (90 °C with plastic spacer)
- Max. working pressure 16 bar (10 bar with plastic spacer).

#### ⓘ INFO

To complete the GE555 module, the following may be ordered separately:

- Thermal energy meter, GE552 series
- Units for domestic/service water, GE550 or GE550-1 series
- Actuator for commanding the zone valve, K270
- Insulation, GE551-4 series
- Components for M-Bus data centralization (GE552-4 series), or Wireless M-Bus data centralization (GE552-W series)

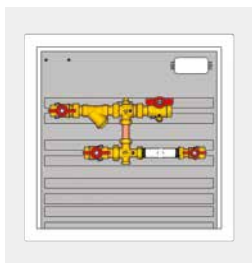

GE555Y461

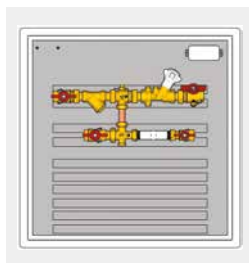

GE555Y462 - GE555Y463

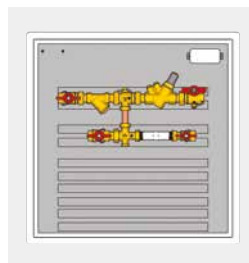

GE555Y468 - GE555Y469

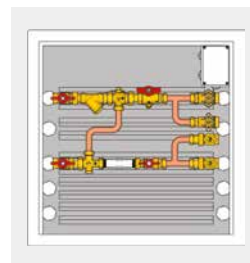



GE555Y472

## GE555-2

MULTIUSER MODULES

### FOR 2 APARTMENTS

PRODUCT CODE	CONNECTIONS	N° OF APARTMENTS		
GE551Y040	3/4" or 1"	2	1	-

GE551Y040 metal cabinet.

It can be used as a multiuser module for centralized heating and/or cooling systems.

- Guide rails for installation of thermal energy metering units (maximum 2 outputs)
- Guide rails for installation of domestic and/or service water metering units (maximum 6 outputs)
- Boxes with terminal boards for electrical connections

Dimensions: 600 x 1100 x 110=160 mm

#### INFO

For use as a multiuser module for 2 apartments, the cabinet must be fitted with the following components:

- Thermal energy metering units, GE550-2 series
- Thermal energy meters, GE552 series
- Units for domestic/service water, GE550 series
- Actuator for commanding the zone valve, K270
- Insulation, GE551-4 series
- Components for M-Bus data centralization (GE552-4 series), or Wireless M-Bus data centralization (GE552-W series)

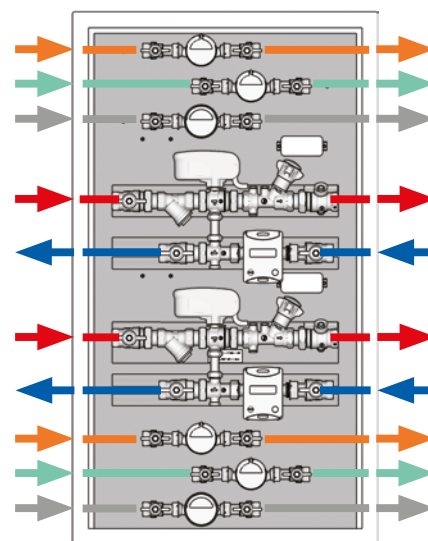

Finishing components, in light grey

DELIVERY



RETURN

DOMESTIC HOT WATER

DOMESTIC COLD WATER

SERVICE WATER

### FOR 3 OR 4 APARTMENTS

PRODUCT CODE	CONNECTIONS	N° OF APARTMENTS		
GE555Y135	3/4" or 1"	3	1	-
GE555Y136	3/4" or 1"	4	1	-

Multiuser module for centralized heating and/or cooling systems.

- Thermal energy metering units (3 or 4 depending on codes)
- Domestic metering units (3 or 4 depending on codes)
- Guide rails for installation of multiuser units (4 outputs) for service water
- Box with terminal board for electrical connections

Dimensions: 750 x 1500 x 190 mm

#### INFO

To complete the MULTIUSER module, the following may be ordered separately:

- Thermal energy meters, GE552 series
- Domestic/service water meters, GE552-2 series
- Multiuser unit (4 outputs) for service water, code GE550Y148
- Actuator for commanding the zone valve, K270
- Insulation, GE551-4 series
- Components for M-Bus data centralization (GE552-4 series)

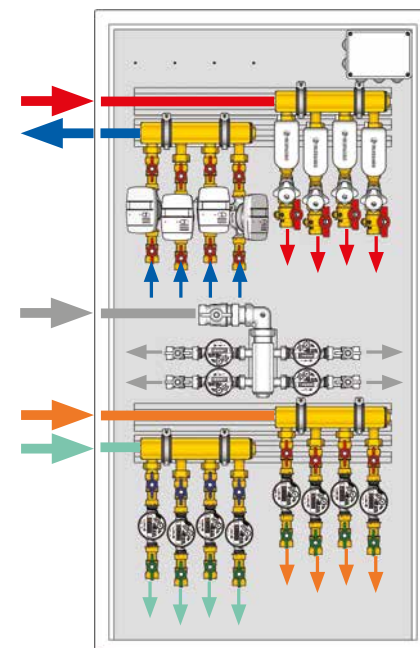

Finishing components, in light grey

Delivery & return metering units.

- Shut-off ball valves
- Plastic spacer for installation of thermal energy meter (the thermal energy meter must be installed splitting the volumetric part from the display)
- Depending on the version, multiuser units for domestic water, heating and/or cooling or universal metallic template units, are available
- Depending on the version, balancing valve units, motorizable zone valve, motorizable mixing valve, are available
- Max. working temperature 110 °C (90 °C with plastic spacer)
- Max. working pressure 16 bar (10 bar with plastic spacer)

## GE550Y147 - GE550Y117

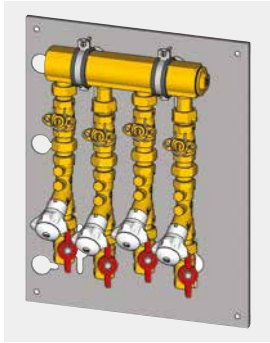

Delivery heating/cooling units.

- Guides to move the position of the collars in vertical direction
- Zone valves (motorizable with K270 actuators)
- Static balancing valves
- Shut-off ball valves with housing for thermal energy meter delivery temperature probe
- Possibility of installation of the fifth zone (code GE550Y094)

Frame dimensions: 390 x 495 x 160 mm

PRODUCT CODE	CONNECTIONS	ZONES		
<b>GE550Y147</b>	1 1/4" x 3/4"	4	1	-
<b>GE550Y117</b>	1 1/4" x 3/4"	3	1	-

## GE550Y146 - GE550Y116



Return heating/cooling units.

- Guides to move the position of the collars in vertical direction
- Plastic spacer for installation of 3/4" thermal energy meters, GE552 series
- Shut-off ball valve
- Possibility of installation of the fifth zone (code GE550Y093)

Frame dimensions: 390 x 495 x 110 mm

PRODUCT CODE	CONNECTIONS	ZONES		
<b>GE550Y146</b>	1 1/4" x 3/4"	4	1	-
<b>GE550Y116</b>	1 1/4" x 3/4"	3	1	-

## GE550Y145 - GE550Y115

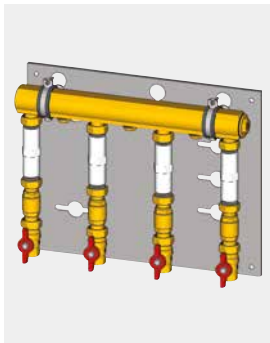

Delivery heating/cooling units.

- Guides to move the position of the collars in vertical direction
- Plastic spacer for installation of circulator 15/7
- Increased port check valves (size 1")
- Shut-off ball valves with housing for thermal energy meter delivery temperature probe
- Possibility of installation of the fifth zone (code GE550Y092)

Frame dimensions: 495 x 390 x 115 mm

PRODUCT CODE	CONNECTIONS	ZONES		
<b>GE550Y145</b>	1 1/4" x 3/4"	4	1	-
<b>GE550Y115</b>	1 1/4" x 3/4"	3	1	-

## GE550Y144 - GE550Y114

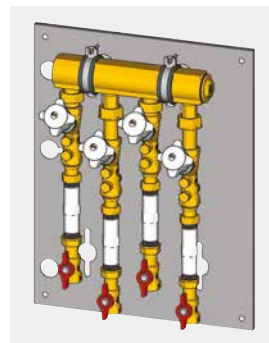

Return heating/cooling units.

- Guides to move the position of the collars in vertical direction
- Static balancing valves
- Plastic spacer for installation of 3/4" thermal energy meters, GE552 series
- Shut-off ball valve
- Possibility of installation of the fifth zone (code GE550Y091)

Frame dimensions: 390 x 495 x 160 mm

PRODUCT CODE	CONNECTIONS	ZONES		
<b>GE550Y144</b>	1 1/4" x 3/4"	4	1	-
<b>GE550Y114</b>	1 1/4" x 3/4"	3	1	-

## GE550Y112 - GE550Y113

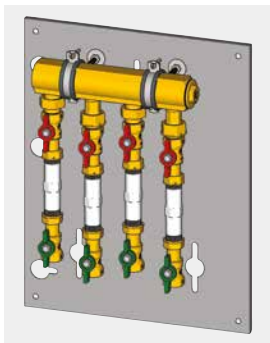

Domestic water units.

- Guides to move the position of the collars in vertical direction
- Plastic spacer for installation of 3/4" water meters, GE552-2 series
- Shut-off ball valves, upstream and downstream of the spacer
- Shut-off valves with check valves (green T-handle)
- Possibility of installation of the fifth zone (code GE550Y090)

Frame dimensions: 390 x 495 x 160 mm

PRODUCT CODE	CONNECTIONS	ZONES		
<b>GE550Y112</b>	1 1/4" x 3/4"	4	1	-
<b>GE550Y113</b>	1 1/4" x 3/4"	3	1	-

## GE550Y149



Universal multiuser metallic frame.

- Metallic frame with insulated manifold (size 1 1/4" x 3/4")
- 2÷4 zones with 3/4" units GE550, GE550-1 or GE550-2 series
- 2÷4 heating/cooling/domestic zones

NOTE: for the manifold-units connection, please order separately the fittings R189DY004

Frame dimensions: 495 x 390 x 115 mm

PRODUCT CODE	CONNECTIONS	ZONES		
<b>GE550Y149</b>	1 1/4" x 3/4"	2÷4	1	-

**GE550Y172 - GE550Y173 - GE550Y174 - GE550Y175 - GE550Y176**

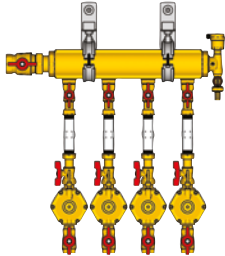

Multiuser heating/cooling module.

- Filter
- Static balancing valve on the delivery outputs
- Differential pressure controller on the return outputs
- Plastic spacer on the return outputs, for installation of GE552 thermal energy meters
- Distribution manifolds with automatic air vent and drain tap

PRODUCT CODE	CONNECTIONS	MANIFOLDS OUTPUTS	DELIVERY MODULE LENGHT mm	RETURN MODULE LENGHT mm		
<b>GE550Y172</b>	1 1/4" x 3/4"	2	750	555	1	-
<b>GE550Y173</b>	1 1/4" x 3/4"	3	750	555	1	-
<b>GE550Y174</b>	1 1/4" x 3/4"	4	750	555	1	-
<b>GE550Y175</b>	1 1/4" x 3/4"	5	850	655	1	-
<b>GE550Y176</b>	1 1/4" x 3/4"	6	950	755	1	-

Delivery module dimensions: 750+950 x 415 x 310 mm  
Return module dimensions: 555+755 x 640 x 310 mm

**GE550Y192 - GE550Y193 - GE550Y194 - GE550Y195 - GE550Y196**

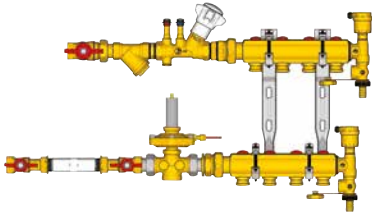

Multiuser heating/cooling module.

- Filter
- Static balancing valve
- Differential pressure controller
- Plastic spacer for installation of GE552 thermal energy meter
- Distribution manifolds with automatic air vent and drain tap

PRODUCT CODE	CONNECTIONS	MANIFOLDS OUTPUTS	LENGHT mm		
<b>GE550Y192</b>	3/4" x base 18	2	585	1	-
<b>GE550Y193</b>	3/4" x base 18	3	635	1	-
<b>GE550Y194</b>	3/4" x base 18	4	685	1	-
<b>GE550Y195</b>	3/4" x base 18	5	735	1	-
<b>GE550Y196</b>	3/4" x base 18	6	785	1	-

Dimensions: 585+785 x 390 x 110 mm

**GE553Y132 - GE553Y133 - GE553Y134 - GE553Y135 - GE553Y136 - GE553Y232 - GE553Y233 - GE553Y234 - GE553Y235 - GE553Y236**

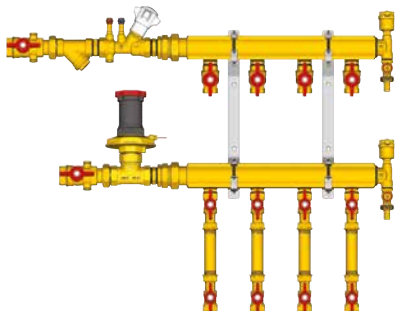

Multiuser heating/cooling module.

- Filter
- Static balancing valve
- Differential pressure controller
- Brass spacer on the return outputs, for installation of GE552 thermal energy meters
- Distribution manifolds with automatic air vent and drain tap

PRODUCT CODE	CONNECTIONS	MANIFOLDS OUTPUTS	LENGHT mm		
<b>GE553Y132</b>	1" x 3/4"	2	630	1	-
<b>GE553Y133</b>	1" x 3/4"	3	730	1	-
<b>GE553Y134</b>	1" x 3/4"	4	830	1	-
<b>GE553Y135</b>	1" x 3/4"	5	930	1	-
<b>GE553Y136</b>	1" x 3/4"	6	1030	1	-
<b>GE553Y232</b>	1 1/4" x 3/4"	2	700	1	-
<b>GE553Y233</b>	1 1/4" x 3/4"	3	800	1	-
<b>GE553Y234</b>	1 1/4" x 3/4"	4	900	1	-
<b>GE553Y235</b>	1 1/4" x 3/4"	5	1000	1	-
<b>GE553Y236</b>	1 1/4" x 3/4"	6	1100	1	-

Dimensions: 625+1100 x 660 x 120 mm

## ➤ Heat interface units for direct metering

### GE556

PRODUCT CODE	CONNECTIONS	MAIN FEATURES	POWER EXCHANGER	☐	☒
GE556Y301	3/4"	Priority valve	44 kW	1	-
GE556Y302	3/4"	Priority valve	58 kW	1	-
GE556Y314	3/4"	Softened water management	44 kW	1	-

Heat Interface Unit (HIU) for centralized systems, for managing heating and domestic hot water production.

- Heat exchanger for instantaneous production of domestic hot water
- Filter and housing for delivery temperature probe, on the primary side
- Motorizable zone valve and lockshield for static balancing, on the heating side
- Pre-arrangement for housing the HIU inside a metallic template fitted with shut-off valves
- Plastic spacers for installation of thermal energy meter and domestic water meter
- Box with terminal board for electric connections
- Fittings for connection and fixing
- Max. working temperature: 90 °C
- Max. working pressure: 16 bar (10 bar with plastic spacer)

Dimensions: 540 x 390 x 155 mm

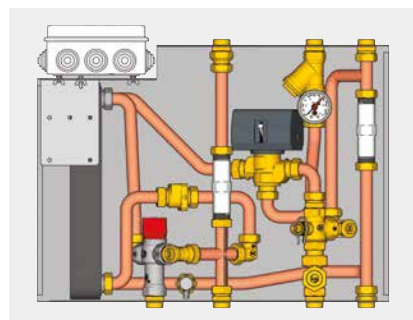

GE556Y301

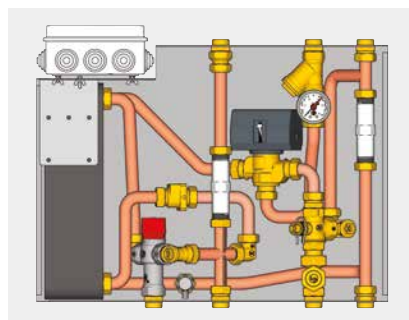

GE556Y302

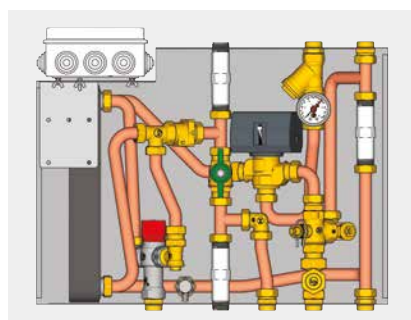

GE556Y314

STANDARD



#### ⓘ INFO

To complete the GE556 HIU, the following may be ordered separately:

- Thermal energy meter, GE552 series
- Domestic water meter, GE552-2 series
- Actuator for commanding the zone valve, K270
- Template for installation in building site, GE551-2 series
- Additional valve kit (only for GE556Y314)
- Components for M-Bus data centralization (GE552-4 series), or Wireless M-Bus data centralization (GE552-W series)

For all the versions, the exchanger power refers to the following operation conditions:

- Primary side 75 °C, flow rate 1 m<sup>3</sup>/h
- Secondary side 15-50 °C, 18 l/min  
(24 l/min for GE556Y302)

For the versions with big exchanger (GE556Y302, GE556Y303), the power can be considered equal to 44kw to the following operating conditions:

- Primary side 65 °C, flow rate 1 m<sup>3</sup>/h
- Secondary side 15-50 °C, 18 l/min

## GE556-1

DOUBLE HEAT EXCHANGER

PRODUCT CODE	CONNECTIONS	MAIN FEATURES	HEAT EXCHANGER POWER	TEMPLATES		
GE556Y171	3/4"	Heating	17,4 kW	GE551Y081	1	-
GE556Y176	3/4"	Heating / Domestic water production	17,4 kW / 56 kW	GE551Y082	1	-
GE556Y177	3/4"	Heating / Domestic water production	17,4 kW / 67 kW	GE551Y082	1	-

Heat Interface Unit (HIU) with a double heat exchanger, for centralized systems for high and low temperature heating and production of domestic hot water (only for GE556Y176-Y177).

- Heat exchanger to separate the secondary heating circuit from the primary circuit of the condominium
- Heat exchanger for the instantaneous production of domestic hot water (except GE556Y171)
- Self-regulating circulator, which conforms to directive ErP (2009/125/EC), expansion tank, safety valve, manometer, pressure switch, automatic air vent valve, on heating side
- Thermostatic control of the heating temperature (possibility of high and low temperature)
- Automated zone valve, on heating side
- Priority control in the production of domestic hot water (except GE556Y171)
- TMV2+TMV3+WRAS-certified anti-scalding thermostatic mixer (except GE556Y171)
- Adjustable by-pass, dynamic balancing valve, primary side (except for the by-pass, there is no primary flow when the HIU is not active), automatic air vent
- Pre-arrangement for housing the HIU inside a metallic template fitted with shut-off valves
- Brass spacers for installation of thermal energy meter and domestic water meter
- Box with terminal board for electric connections
- Max. working temperature: 90 °C
- Max. working pressure: 16 bar

Dimensions: 450 x 630 x 180 mm



### INFO

To complete the GE556-1 HIU, the following may be ordered separately:

- Thermal energy meter, GE552 series
- Domestic water meter, GE552-2 series
- Actuator for commanding the zone valve, K270
- Template for installation in building site, GE551 series
- Components for M-Bus data centralization (GE552-4 series), or Wireless M-Bus data centralization (GE552-W series)

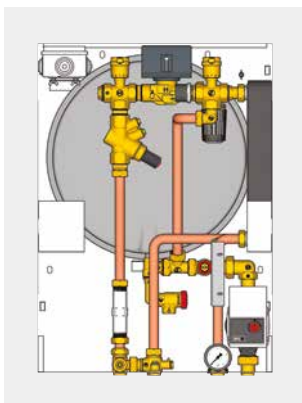

GE556Y171

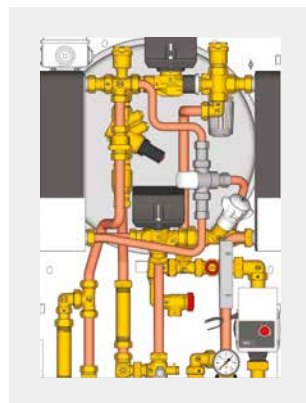

GE556Y176 - GE556Y177



# GE556-2

PRODUCT CODE	CONNECTIONS	MAIN FEATURES	EXCHANGER POWER	TEMPLATES		
GE556Y401	3/4"	Heating / Domestic water production	58 kW	GE551Y074	1	-
GE556Y402	3/4"	Heating / Domestic water production	67 kW	GE551Y074	1	-

High-efficiency electronic Heat Interface Unit (HIU) for centralized systems, for managing high/low temperature heating and hot domestic water production.

- Heat exchanger for the instantaneous production of domestic hot water
- Flow switch for domestic hot water priority command
- Three-way motorized diverting valve
- Two-way motorized mixing valve
- Self-modulating circulator complying with ErP Directive (2009/125/EC)
- Filter and manual air-vent valve on primary side
- Adjustable by-pass and static balancing lockshield on heating side
- Thermal safety valve on heating side
- Safety pressure switch for low pressure
- Fully insulated pipes
- Electronic thermoregulation unit with fixed point (Set-Point) for managing the domestic hot water temperature and the climatic heating curve, with external probe support (included)
- Remote command for parameter management, with visualisation display
- Domestic hot water temperature control probes (heating and primary return)
- Box with terminal board for electric connections
- Brass and plastic spacers for installation of thermal energy meter and domestic water meter
- Energy savings: reduction of the flow rate requested from the primary line, and reduction of the primary return temperatures
- Heating temperature range: low temperature: 25+45 °C / high temperature: 25+85 °C
- Domestic hot water temperature range: 30+60 °C (Set-Point 48 °C)
- Max. working temperature: 90 °C
- Max. working pressure: 6 bar

Dimensions: 450 x 630 x 180 mm



**INFO**

To complete the GE556-2 HIU, the following may be ordered separately:

- Thermal energy meter, GE552 series
- Domestic water meter, GE552-2 series
- Templates for installation in building site, GE551-2 series
- Components for M-Bus data centralization (GE552-4 series), or Wireless M-Bus data centralization (GE552-W series)

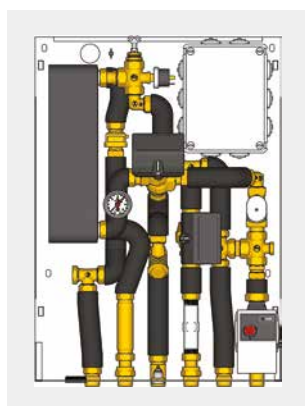

GE556Y401 - GE556Y402



**K480Y002**  
Thermostat with remote command. Provided with the HIU

**ENERGY SAVING FEATURES**

Low return temperatures of primary side, in heating operation

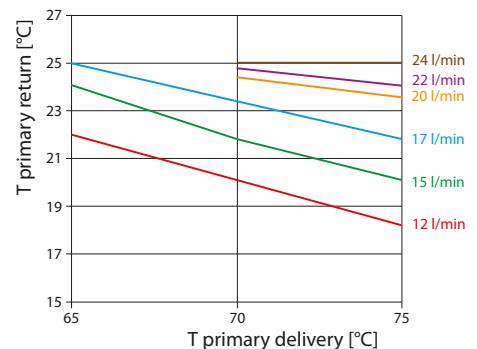

## GE556-4

WITH DIFFERENTIAL PRESSURE CONTROL VALVE

PRODUCT CODE	CONNECTIONS	MAIN FEATURES	EXCHANGER POWER	TEMPLATES		
GE556Y320	3/4"	High temperature heating/ Domestic water production	17,4 kW	GE551Y075	1	-
GE556Y321	3/4"	High temperature heating/ Domestic water production		GE551Y075		
GE556Y322	3/4"	Low temperature heating/ Domestic water production	17,4 kW / 56 kW	GE551Y075	1	-
GE556Y323	3/4"	Low temperature heating/ Domestic water production	17,4 kW / 67 kW	GE551Y075	1	-

Heat Interface Unit (HIU) for centralized systems, for managing high/low temperature heating and hot domestic water production.

- Heat exchanger for instantaneous production of domestic hot water
- Flow switch for domestic hot water priority control
- Motorized three-way diverting valve
- Self-modulating circulator complying with Directive ErP 2009/125/EC (only for GE556Y322-323)
- Static balancing valve (only for GE556Y320-321)
- Thermostatic valve for adjusting the domestic hot water and heating temperature
- By-pass on the Domestic primary side to keep the exchanger warm
- Automatic air vent valve with hygroscopic gasket, filter and manometer on the primary side
- Safety pressure switch for low pressure on the primary side (only for GE556Y322-323)
- Differential pressure control valve on the primary side
- Safety valve with electrical actuator on the heating side
- Box with terminal board for electric connections
- Brass spacers for installation of thermal energy meter and domestic water meter
- Max. working temperature: 90 °C
- Max. working pressure: 6 bar (for low temp. versions); 16 bar (for high temp. versions)

Dimensions: 450 x 630 x 180 mm



### INFO

To complete the GE556-4 HIU, the following may be ordered separately:

- Thermal energy meter, GE552 series
- Domestic water meter, GE552-2 series
- Templates for installation in building site, GE551-2 series
- Components for M-Bus data centralization (GE552-4 series), or Wireless M-Bus data centralization (GE552-W series)

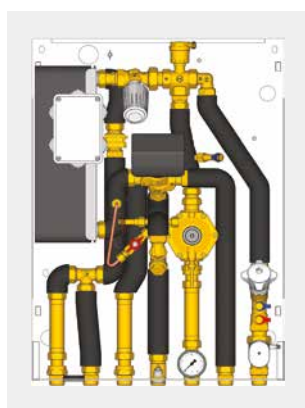

GE556Y320 - GE556Y321

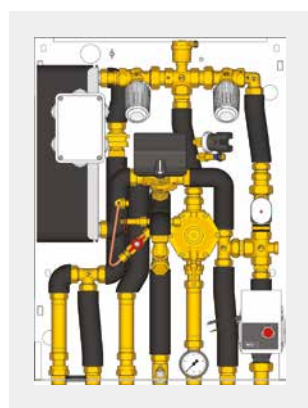

GE556Y322 - GE556Y323

## CONFIGURATION EXAMPLES



SM556Y04929



SM556Y05233



SM556Y05336

Modular Heat Interface Units (HIU) for thermal energy consumptions in heating systems and domestic hot water production in modern autonomous systems with centralized heat production (eg. teleheating).

GE556-5 heat interface units are known as modular as one can assemble various components to create an interface unit suitable based on installation needs (control of high or low temperature heating with or without balancing valves, control of domestic hot and/or cold water, etc...).

### Main features

- Hydraulic connection: 3/4" M.
- Heat exchanger power for domestic water up to 50 kW.
- Priority valve for domestic water production.
- Insulation through polypropylene foam shell.
- Predisposition for installation of thermal energy meter and domestic water meters.

### Optional features

- Upper or lower primary circuit inlet.
- Differential pressure control valve on primary circuit.
- Domestic hot water control through thermostatic head.
- Flow rate control of high temperature heating circuit through static balancing valve.
- Additional low temperature heating circuit with thermostatic head and circulator, ERP compliance.
- Thermostatic by-pass to maintain constant the domestic hot water temperature of the heat exchanger
- Recirculation kit with or without circulator for domestic water circuit.
- Varnished metal cover aesthetically pleasant.



VIDEO TUTORIAL

### INFO

For the realization of the purchase code of the desired configuration, please refer to our sales back office.

Configuration examples (shown in the images):



















- SM556Y04929:  
GE556Y501 + GE556Y516 + GE556Y522 + GE556Y531 + GE556Y541
- SM556Y05233:  
GE556Y501 + GE556Y516 + GE556Y522 + GE556Y532 + GE556Y542 + GE556Y551
- SM556Y05336:  
GE556Y501 + GE556Y516 + GE556Y522 + GE556Y532 + GE556Y543 + GE556Y546 + GE556Y551 + GE556Y561 + GE556Y566

### Technical data

- Max. working temperature of primary and secondary circuits (heating and domestic hot water): 90 °C
- Max. working pressure of primary circuit: 6 bar
- Max. differential pressure of primary circuit: 0.5 bar
- Max. working pressure of domestic hot water (DHW) circuit: 10 bar
- Temperature range of heating secondary circuit: 20÷70 °C (set point 45 °C)
- Temperature range of domestic hot water (DHW) secondary circuit: 20÷70 °C (set point 50 °C)
- Nominal flow rate of primary circuit (domestic hot water production):
  - With GE556Y511/512 heat exchanger 515 l/h @ 80 °C for 34 kW
  - With GE556Y513/514 heat exchanger 620 l/h @ 80 °C for 42 kW
  - With GE556Y515/516 heat exchanger 720 l/h @ 80 °C for 50 kW
- Nominal flow rate of high temperature heating circuit:
  - With GE556Y541/542 kit 1000 l/h @  $\Delta T$  15 °C (80-65 °C) for 17,5 kW
  - With GE556Y543 kit 480 l/h @  $\Delta T$  10 °C (80-70 °C) for 5,5 kW
- Nominal flow rate of low temperature heating circuit:
  - With GE556Y546 kit 1500 l/h @  $\Delta T$  7 °C (45-38 °C) for 12,5 kW
- Nominal flow rate of high and low temperature heating circuit:
  - With GE556Y542 + GE556Y546 kit
    - Primary: 770 l/h @ 80-54,5 °C for 23 kW
    - Low temp. secondary circuit: 1500 l/h @  $\Delta T$  7 °C (45-38 °C) for 12,5 kW
    - High temp. secondary circuit: 600 l/h @  $\Delta T$  15 °C (80-65 °C) for 10 kW
  - With GE556Y543 + GE556Y546 kit
    - Primary circuit: 680 l/h @ 80-56 °C for 19 kW
    - Low temp. secondary circuit: 1500 l/h @  $\Delta T$  7 °C (45-38 °C) for 12,5 kW
    - High temp. secondary circuit: 480 l/h @  $\Delta T$  10 °C (80-70 °C) for 5,5 kW

## HOW TO CREATE THE DESIRED HIU

Starting from the GE556Y501/502 basic codes, the heat interface unit can be configured with additional product codes and possible optionals.

BASIC CODE	DOMESTIC WATER CIRCUIT		PRIMARY CIRCUIT	SECONDARY CIRCUIT	OPTIONALS	
	HEAT EXCHANGER	CONTROL COMPONENTS			INSULATION	OTHER OPTIONALS
<b>GE556Y501</b> Lower primary connections 	<b>GE556Y511</b> 16-plate exchanger + 5 mm insulation 	<b>GE556Y521</b> DHW production with no controls 	<b>GE556Y531</b> Primary circuit connections with no controls 	<b>GE556Y541</b> Secondary circuit, direct heating with no controls 	<b>GE556Y551</b> Insulation 	<b>GE556Y561</b> DCW outlet unit output 
<b>GE556Y502</b> Upper primary connections 	<b>GE556Y512</b> 16-plate exchanger + 20 mm insulation 	<b>GE556Y522</b> DHW production with thermostatic control 	<b>GE556Y532</b> Primary circuit connections with differential pressure control valve 	<b>GE556Y542</b> Secondary circuit, direct heating with static balancing 		<b>GE556Y562</b> Domestic water recirculation unit output with circulator 
	<b>GE556Y513</b> 26-plate exchanger + 5 mm insulation  <b>GE556Y514</b> 26-plate exchanger + 20 mm insulation  <b>GE556Y515</b> 36-plate exchanger + 5 mm insulation  <b>GE556Y516</b> 36-plate exchanger + 20 mm insulation			<b>GE556Y543</b> Secondary circuit, direct heating with presetting valve, possible installation of thermo-electric actuator 		<b>GE556Y563</b> Domestic water recirculation unit output without circulator 
				<b>GE556Y546</b> Secondary circuit, low temperature heating kit (circulator + thermostatic head) 		<b>GE556Y566</b> Thermostatic by-pass to maintain constant the DHW temperature of the heat exchanger 
				① The GE556Y546 kit can be ordered separately or combined to one of the GE556Y541/542/543 kits.		<b>GE556Y569</b> Drain cocks 

To complete the GE556-5 HIU, the following may be ordered separately:

<b>GE551Y078</b> Template with 6 shut-off valves, for GE556Y501 or GE556Y502 HIU including GE556Y551 insulation 	<b>GE551Y079</b> Lowered template with 6 shut-off valves, for GE556Y501 or GE556Y502 HIU without insulation 	<b>GE500Y254</b> Additional DCW valve, for installation on template with GE556Y561 optional kit 	<b>GE500Y255</b> Pair of additional valves for low temperat. heating delivery and return, for installation on template with GE556Y546 kit for secondary circuit 	<b>GE551Y170</b> Metal cover for HIU, only for HIU with GE551Y078 template 	<b>R473/R473M</b> Thermo-electric actuator normally closed to control presetting valve, included with GE556Y543 kit R473X221-R473MX221: 230 V R473X222-R473MX222: 24 V 	<b>GE552</b> Thermal energy meter GE552Y159 3/4", volumetric, 1.5 m³/h GE552Y216 3/4", volumetric, 1.5 m³/h with wireless M-Bus predisposition GE552Y122 3/4", ultrasounds, 1.5 m³/h 	<b>GE552-2</b> Domestic water meter GE552Y191 3/4", domestic hot water GE552Y190 3/4", domestic cold water, to be ordered separately if GE556Y561 additional unit output is present 
--	---	--	--	--	--	---	--

① Second to last number of each product code (in red in the table) indicates product type:

- 0 for heat interface unit base
- 1 for heat exchanger of domestic water circuit
- 2 for control components of domestic water circuit
- 3 for control components of primary circuit
- 4 for control components of secondary circuit (heating)
- 5 for insulation (optional)
- 6 for other optional components

To ensure proper operation of heat interface unit, order at least one product code for each type of component with 0, 1, 2, 3, 4 as second to last figure. Product codes with 5, 6 as second to last figures are considered optionals.

# GE556-6

PRODUCT CODE	CONNECTIONS	MAIN FEATURES	EXCHANGER POWER	TEMPLATES		
GE556Y411	3/4"	Heating / Domestic water production	56 kW	GE551Y085 GE551Y086	1	-
GE556Y412	3/4"	Heating / Domestic water production	67 kW	GE551Y085 GE551Y086	1	-

Electronic Heat Interface Unit (HIU) with double heat exchanger for centralized systems, for managing high/low temperature heating and domestic hot water production.

- Heat exchanger to separate the secondary heating circuit from the primary circuit of the condominium
- Heat exchanger for the instantaneous production of domestic hot water
- Electronic thermoregulation unit with fixed point (Set-Point) for managing the domestic hot water temperature and the climatic heating curve, with external probe support (included)
- Remote control with chronothermostat function to manage the parameter (for single zone)
- Flow switch for domestic hot water priority command
- Three-way priority valve on the delivery of the primary side
- Two-way modulating valve on the return of the primary side
- Self-modulating circulator (ErP 2009/125/EC)
- Filter and automatic air-vent valve on primary side
- Safety valve on heating side
- Safety pressure switch for low pressure on the primary side
- Fully insulated pipes
- Box with terminal board for electric connections
- Multizone additional control by the free contact on the electronic board (additional thermostats to be ordered separately)
- Brass spacers for installation of thermal energy meter and domestic water meter
- Energy savings: reduction of the flow rate requested from the primary line, and reduction of the primary return temperatures
- Heating temperature range: low temperature: 25+45 °C / high temperature: 25+85 °C
- Domestic hot water temperature range: 30+60 °C (Set-point 50 °C)
- Max. working temperature: 90 °C
- Max. working pressure: 10 bar

Dimensions: 460 x 630 x 270 mm

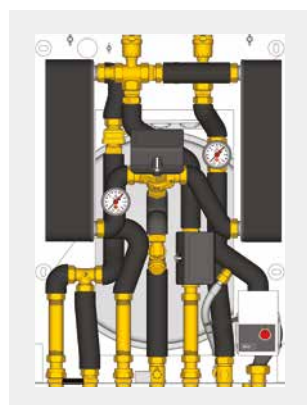

GE556Y411 - GE556Y412



**K480Y002**  
Thermostat with remote command.  
Provided with the HIU



### INFO

To complete the GE556-6 HIU, the following may be ordered separately:

- Thermal energy meter, GE552 series
- Domestic water meter, GE552-2 series
- Templates for installation in building site
- Components for M-Bus data centralization (GE552-4 series), or Wireless M-Bus data centralization (GE552-W series)

### ENERGY SAVING FEATURES

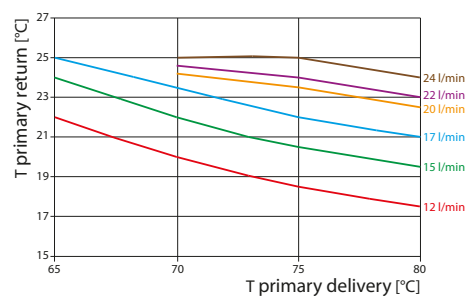

Low return temperatures of primary side, in heating operation



# ➤ Thermal energy meters, water meters, data centralization systems

## GE552

### THERMAL ENERGY METERS

PRODUCT CODE	CONNECTIONS	NOMINAL FLOW-RATE m <sup>3</sup> /h	MAX FLOW-RATE m <sup>3</sup> /h	SUPPLY	DISTANCE m	DATA CENTRALIZATION TYPE		
GE552Y215	3/4"	0,6	1,2	battery	110	M-Bus / Wireless M-Bus	1	-
GE552Y216	3/4"	1,5	3	battery	110	M-Bus / Wireless M-Bus	1	-
GE552Y217	1"	2,5	5	battery	130	M-Bus / Wireless M-Bus	1	-

Volumetric thermal energy meters with double register, for measuring heating and/or cooling consumption.



- Electronic processing unit
- Flow rate measuring section
- Impulsive inputs for domestic water meters
- Two water temperature probes (delivery and return)
- Max. working temperature 90 °C
- Max. working pressure 16 bar
- Arranged for data communication in accordance with M-Bus EN1434 or Wireless M-Bus EN13757 (by the GE552Y027 board)
- EC marks
- Certified in accordance with MID 2014/32/EU



GE552Y215 - GE552Y216 - GE552Y217

## GE552-2

### DOMESTIC WATER METERS

PRODUCT CODE	CONNECTIONS	DOMESTIC WATER TYPE	PERMANENT FLOW-RATE Q3 m <sup>3</sup> /h	MAX. WATER TEMPERATURE °C	CENTRE DISTANCE mm	DATA CENTRALIZATION TYPE		
GE552Y190	3/4"	cold	2,5	30	110	M-Bus	1	-
GE552Y191	3/4"	hot	2,5	90	110	M-Bus	1	-

Domestic water meters, for measuring the consumption of domestic hot and cold water.

- Measurement section of the flow and circular dial
- Max. working temperature: 30 °C for domestic cold water  
90 °C for domestic hot water
- Max. working pressure 16 bar
- Arranged for data communication in accordance with M-Bus EN1434
- EC marking
- Certified in accordance with MID 2014/32/EU



GE552Y190 - GE552Y191

The wireless M-Bus (868 MHz) centralization complies with the standard EN 13757. The consumption data may be sent remotely or in walk-by mode.

## REMOTE MODE

The new modular M-Bus Wireless centralization system is composed of a datalogger GE552Y052 (with integrated web server) and radio signal repeater antennae GE552Y053. The system allows:

- connecting in series the various wired and wireless devices, extending the reading capacity up to 500 devices.
- directly managing 500 wireless devices or 20 wired devices and 480 wireless.

The number of wired devices may be extended to 250, connecting more local concentrators GE552Y050 to the GE552Y052 datalogger, maintaining the possibility to manage up to 250 wireless devices.

Advantages:

- The integrated web server allows the set-up, the search and the consultation of data from all the devices that make up the M-Bus/M-Bus wireless network directly on the display of the device
- Through a dial-up router all data can be managed and viewed on a PC or smartphone
- Management of alarms due to failure, tampering or the exceeding of configurable thresholds with the sending of email notifications
- Scheduling for the generation and forwarding of reports on the data gathered

## WIRELESS DATALOGGER



Wireless M-Bus/M-Bus datalogger for acquisition, processing and registration of data from wired or wireless M-Bus devices.

PRODUCT CODE		
<b>GE550Y117</b>	1	-

Manages directly up to 500 wireless devices and 20 wired devices.

## WIRELESS SIGNAL REPEATER ANTENNA



Wireless repeater and concentrator to extend the radio flow rate of the devices and for data transmission to the GE552Y052 datalogger.

PRODUCT CODE		
<b>GE552Y053</b>	1	-

## MODEM ROUTER



3G/EDGE/GPRS wireless modem router for remote connection of GE552Y051 or GE552Y052 datalogger.

PRODUCT CODE		
<b>GE552Y055</b>	1	-

## WALK-BY MODE

Data sent to a PC, received by antenna GE552Y043 connected to USB port.

## WIRELESS DATA RECEIVE



Wireless data receiver for devices installed on the installation (heat cost allocators, wireless modules for meters). Can be connected to PC via USB port. Flow rate up to 400 m.

PRODUCT CODE		
<b>GE552Y043</b>	1	-

The operation is provided by the same software GESWY001 used for heat cost allocators programming.

## WIRELESS DEVICES

### WIRELESS MODULE FOR THERMAL ENERGY METERS



For installation on the thermal energy meter dial GE552Y215, GE552Y216, GE552Y217.

PRODUCT CODE		
GE552Y027	1	-

### SOFTWARE FOR WIRELESS DATA CENTRALISATION

PRODUCT CODE		
GESWY001	1	-

The software can be used to configure and easily manage the wireless metering system.

It is suitable for all devices.

The codes refers to no. 1 user license.

### SAMPLE SCHEME

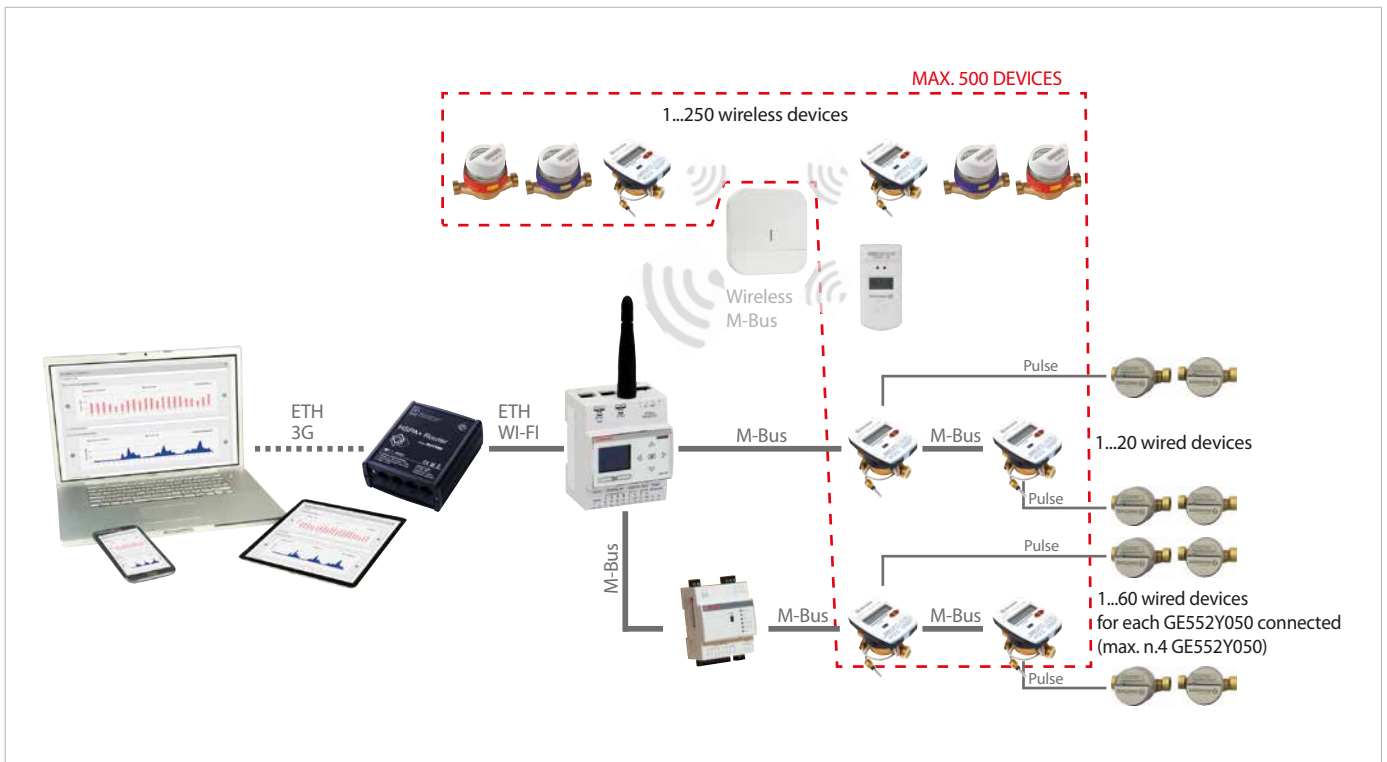

### GE500



Probe-support replacement kit M10 x 1 mm for energy meters.

PRODUCT CODE	SIZE		
GE500Y401	brass	1	-
GE500Y402	plastic		



The new M-bus modular centralization system comprises two solutions and allows to place the various devices in series expanding the reading possibility from 60 to 250 devices.

The standard solution is to use a local M-Bus concentrator that supports up to 60 devices and allows the on-site consultation and acquisition of data on the PC through a special software and USB cable. Up to 4 local concentrators can be placed in series and therefore up to 240 devices managed. The complete solution consists of a datalogger with integrated web server that supports up to 4 local concentrators expanding the network to 250 devices.

Advantages:

- The integrated web server allows the set-up, the search and the consultation of data from all the devices that make up the M-Bus network directly on the display of the device
- Through a dial-up router all data can be managed and viewed on a PC or smartphone
- Management of alarms due to failure, tampering or the exceeding of configurable thresholds with the sending of email notifications
- Scheduling for the generation and forwarding of reports on the data gathered

## LOCAL CONCENTRATOR



Local concentrator for the collection, processing and recording of data originated from the M-Bus network. Capable of managing up to 60 devices. To be used with the software for data acquisition GE552Y056.

PRODUCT CODE		
GE552Y050	1	-
GE552Y056*		

\* The code refers to no. 1 user license.

## DATALOGGER WITH WEB SERVER



M-Bus datalogger for the collection, processing and recording of data originating from local GE552Y050 concentrators (max. 4 concentrators). Can manage directly up to 20 devices and expands the M-Bus network up to 250 devices.

PRODUCT CODE		
GE552Y051	1	-

## MODEM ROUTER



3G/EDGE/GPRS wireless modem router for remote connection of GE552Y051 or GE552Y052 datalogger.

PRODUCT CODE		
GE552Y055	1	-

## SAMPLE SCHEME

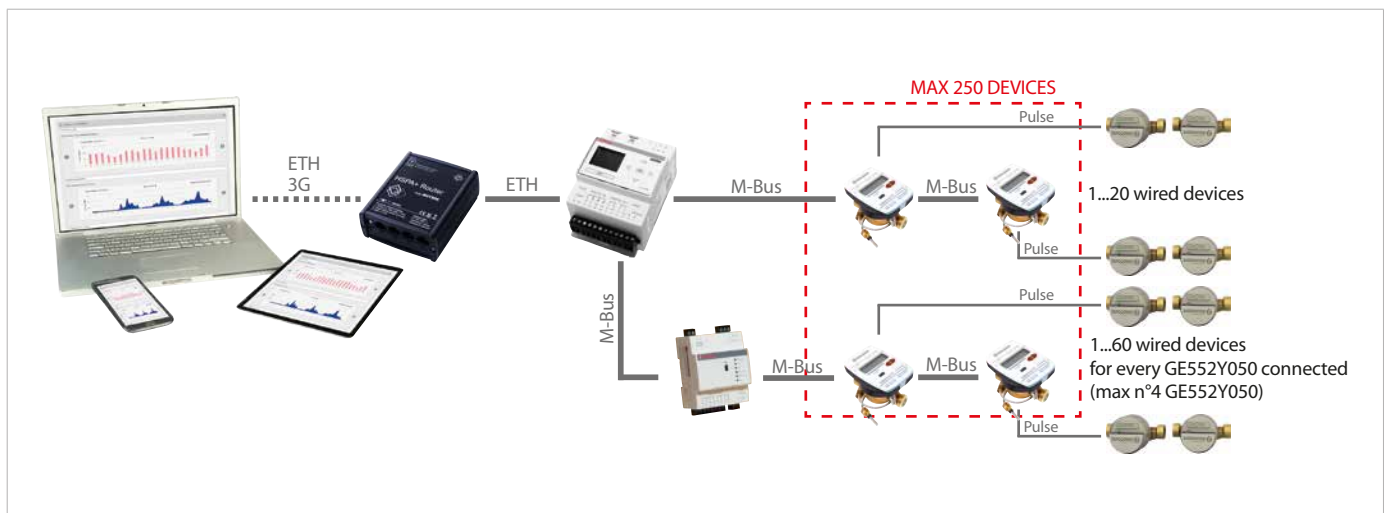

## DATA CENTRALIZATION WITH M-BUS

The European Parliament and Council of the European Union have adopted Directive 2014/32/EU concerning measurement instruments (MID – Measurement Instrument Directive): it sets the requirements for a set of devices and measurement systems in order to be marketed and operated in UE countries.

All measurement devices used in GE555 modules and GE556 HIUs comply with MID European Directive.

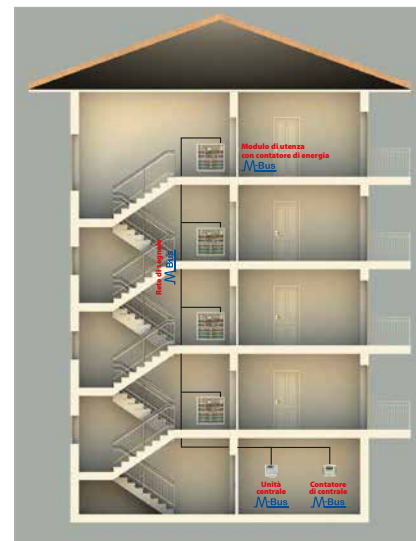

## COMPLIANCE WITH MID DIRECTIVE (2014/32/EU)

The use of measurement instruments suitable for the recording of consumption data is particularly important for the aspects that involves, as the consumer and environment protection, the fair expense sharing out, the imposition of taxes or the correctness of the commercial transactions.

For this reason, the Countries of the European Union have acknowledged MID Directive (2014/32/EU) that defines the requirements to which the measurement instruments shall comply with to be marketed or started.

The range of Giacomini's modules and user HIUs includes exclusively measurement devices complying with the Directive, as attested on them by the presence of the MID metrological marking close by the CE marking.



## METROLOGICAL MARKING

Compliance of measurement devices with all provisions of D.Lgs. 2nd February 2007 n.22 is certified by the presence, on them, of CE marking and of metrology marking composed of letter "M" and of the last two digits of the year of production.



## OMS: Open Metering System

The Open Metering System (OMS) is the only specification in Europe intended to integrate the instruments for measuring various elements, to guarantee their interoperability and future operation. The water and heat meters and the heat cost allocators using an open communication standard are interchangeable regardless of the producer and guarantee maximum safety and data protection levels.



## ➤ Indirect metering (heat cost allocators)

The metering of thermal consumption using the GE700 electronic heat cost allocator system allows reorganizing radiator systems with centralized production and rising column distribution, making them more modern and appropriate for the times. In addition to the comfort and energy saving provided by individual thermoregulation using thermostatic heads and valves, it is possible to divide the cost of heating on the basis of the actual consumption, with a criterion of greater equity with respect to the traditional criteria of subdividing. A radiator system that is reorganized with metering and thermoregulation also encourages more responsible, individual behaviour towards energy use. By paying for what they actually consume, each user is motivated to eliminate waste and to regulate the temperature inside the rooms of his house, on the basis of his actual need. No longer will rooms be unnecessarily overheated, with the windows open, which will be a great benefit for the environment and for the energy bill. The GE700 electronic heat cost allocators conform to regulation EN 834, and are based on the principle of dual-sensor temperature measurement. Their use is possible in radiator systems that have single, or twin pipe distribution. They can also transmit the data remotely, at a radio frequency of 868 MHz (the ISM (Industrial, Scientific, Medical) European band) and are fitted with a long-life battery. The large range of accessories allow them to be assembled to the most common radiators on the market.



### GE700

PRODUCT CODE	FEATURES		
GE700Y030	-	1	-
GE700Y033	with remote sensor	1	-

Radio-controlled heat cost allocator, for measuring thermal consumption. With certification of conformity to the norm EN 834. EN 13757 Wireless M-Bus transmission of data at 868 MHz in accordance with OMS standard. Six-figure display for direct reading. Dual temperature sensor operation, with automatic switching to one sensor under critical temperature measuring conditions. Optical interface for programming/reading using a special configuration key. Anti-tamper seal and alarm disassembly with data storage. Daily storage of data, with monthly archive. Archive of consumptions and average temperatures, up to 24 months before. Powered by a lithium battery, standard lifetime, 10 years.

- Type of centralized system: with 2 pipes / 1 pipe.
- Sensor precision: error  $\leq 1\%$ .
- Heating temperature field (Tmin for initial count, Tmax): 21+90 °C.
- Temperature for initial count, summer mode: 38 °C.
- Switching  $\Delta T$ : 3 K.
- Maximum radiator power: 12500 W.
- Programmable data transmission frequency.
- Transmission power  $\leq 10$  mW.
- Warehouse storage temperature: 10+30 °C.
- Standard OMS.

Production check of every individual heat cost allocator. Certification document of the count precision, available (in accordance with EN 834).

#### HEAT COST ALLOCATORS

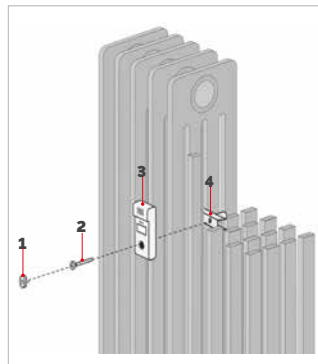
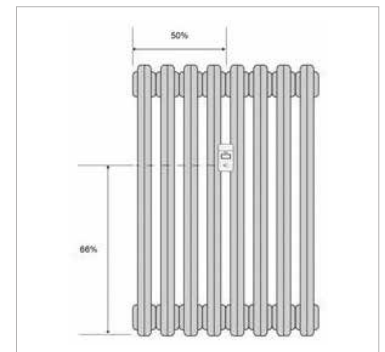

1 = SAFETY SEAL - 2 = FIXING SCREWS  
3 = HEAT COST ALLOCATOR - 4 = SUPPORT

#### ① INFO

GE700Y033: radio-controlled heat cost allocator with remote sensor. To be used in installation situations in which the radiator is difficult to access, or where there is insufficient space to fit the heat cost allocator. In these cases, the heat cost allocator and probe can be installed separately, with the remote sensor in contact with the surface of the radiator. Includes probe and kit to fit the heat cost allocator to the wall. Suitable for measuring thermal consumption in convectors. Remote probe cable length: 2 m.

## GE700-1

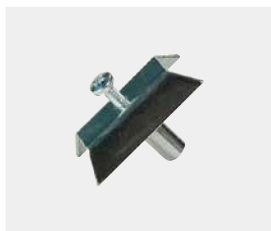

Fixing elements for GE700 heat cost allocators.

PRODUCT CODE	SIZE	☐	☒
GE700Y100	35 mm fixing support, M4 screws x30	1	20
GE700Y101	43 mm fixing support, M4 screws x30	1	20
GE700Y102	53 mm fixing support, M4 screws x30	1	20
GE700Y103	55 mm fixing support, M3 screws x30	1	20
GE700Y104	37 mm fixing support, M3 screws x30	1	20
GE700Y105	67 mm fixing support, M4 screws x30	1	20
GE700Y106	Bracket	1	20
GE700Y107	Threaded stud bolt	1	20
GE700Y108	Screw nut for the welding operation	1	20
GE700Y109	Spanner for tightening the GE700Y108 nut	1	-
GE700Y110	Additional plate for installing onto radiators that have a large space between the elements	1	20
GE700Y801	Welder	1	-

## GE700-2



Optical key, for configuring the GE700 heat cost allocators. Can be connected to a USB port, and programmed using specific software for heat cost allocators (GESWY001).

\* The code refers to no. 1 user license.

PRODUCT CODE	SIZE	☐	☒
GE700Y150	optical key	1	-
GESWY001 *	software	1	-

## GE552-W

### WIRELESS M-BUS CENTRALIZATION

The centralisation of the wireless M-Bus (868 MHz) complies with EN 13757. The consumption data may be sent remotely or in walk-by mode.

#### REMOTE MODE

The data received by the GE552Y053 is sent to the datalogger GE552Y052, allowing:

- the remote transmission of read data to programmable e-mail addresses;
- the management and display of the data from the PC, smartphone or tablet, through integrated web server if connected to the GSM/GPRS network.

#### WIRELESS DATALOGGER



Wireless M-Bus / M-Bus datalogger for collection, processing and recording of data from wired or wireless M-Bus devices. Manages directly up to 500 wireless devices and 20 wired devices.

PRODUCT CODE	☐	☒
GE552Y052	1	-

#### WIRELESS SIGNAL REPEATER ANTENNA



Wireless repeater and concentrator to extend the radio flow rate of the devices and for data transmission to the GE552Y052 datalogger.

PRODUCT CODE	☐	☒
GE552Y053	1	-

#### WALK-BY MODE

Data sent to a PC, received by GE552Y043 antenna connected to USB port.

#### WIRELESS DATA RECEIVE



Wireless data receiver for devices installed on the installation (heat cost allocators, wireless modules for meters). Can be connected to PC via USB port. Flow rate up to 400 m.

PRODUCT CODE	☐	☒
GE552Y043	1	-

The operation is provided by the same software GESWY001 used for heat cost allocators programming.

## ➤ Basic units and accessories (boxes, templates, insulations, other components)

### GE550

UNITS FOR DOMESTIC WATER

PRODUCT CODE	CONNECTIONS	TYPE OF DOMESTIC WATER	PERMANENT FLOW-RATE m <sup>3</sup> /h	MAX. WATER TEMPERATURE	WATER METER	COLLARS	UNITS LENGHT mm	☐	☒
GE550Y004	3/4"	cold	2,5	30 °C	YES	included	262	1	-
GE550Y005	1"	cold	4	30 °C	YES	included	310	1	-
GE550Y014	3/4"	hot	2,5	90 °C	YES	included	262	1	-
GE550Y015	1"	hot	4	90 °C	YES	included	310	1	-
GE550Y008	3/4"	cold - service water	2,5	30 °C	YES	included	262	1	-
GE550Y101	3/4"	cold	-	-	NO	included	262	1	-
GE550Y102	1"	cold	-	-	NO	included	310	1	-
GE550Y103	3/4"	hot	-	-	NO	included	262	1	-
GE550Y104	1"	hot	-	-	NO	included	310	1	-

Domestic water metering units.

- Shut-off ball valves
- Check valve integrated with the shut-off ball valve (green handle)
- Available with or without water meter
- Max. working temperature:  
30 °C for cold domestic water  
90 °C for hot domestic water
- Max. working pressure: 16 bar (10 bar with plastic spacer)

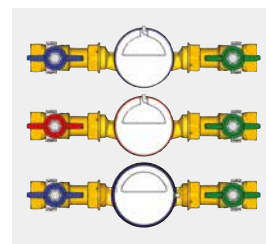

GE550Y004 - GE550Y005  
GE550Y014 - GE550Y015  
GE550Y008

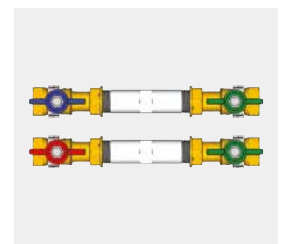

GE556Y411 - GE556Y412

### GE550-1

GROUPS FOR DOMESTIC WATER WITH THERMOSTATIC MIXER

PRODUCT CODE	CONNECTIONS	TYPE OF DOMESTIC WATER	PERMANENT FLOW-RATE m <sup>3</sup> /h	MAX. WATER TEMPERATURE	WATER METER	COLLARS	UNITS LENGHT mm	☐	☒
GE550Y024	3/4"	cold + hot	2,5	90 °C (hot side)	YES	included	420	1	-
GE550Y111	3/4"	cold + hot	2,5	90 °C (hot side)	NO	included	420	1	-

Domestic water metering units, with thermostatic mixer.

- Shut-off ball valves
- Check valve
- Available with or without water meter
- Max. working temperature:  
30 °C on cold domestic water side  
90 °C on hot domestic water side
- Max. working pressure: 16 bar (10 bar with plastic spacer)

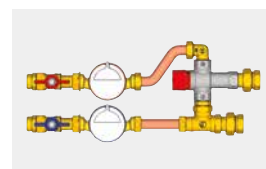

GE550Y024

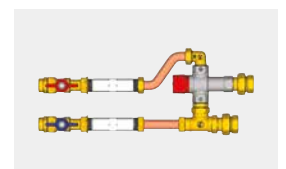

GE550Y111

## DELIVERY UNITS

PRODUCT CODE	CONNECTIONS	NOMINAL FLOW-RATE m <sup>3</sup> /h	ZONE VALVES	BALANCING VALVES	FILTER	COLLARS	UNITS LENGHT mm		
GE550Y121	3/4"	1,5	NO	NO	YES	included	264	1	-
GE550Y122	1"	2,5	NO	NO	YES	included	316	1	-
GE550Y123	3/4"	1,5	2 ways	NO	NO	included	237	1	-
GE550Y124	3/4"	1,5	2 ways	NO	YES	included	320	1	-
GE550Y125	1"	2,5	2 ways	NO	YES	included	371	1	-
GE550Y135	1"	2,5	2 ways	YES	YES	included	508	1	-
GE550Y136	3/4"	1,5	2 ways	YES	YES	included	439	1	-
GE550Y137	3/4"	1,5	NO	YES	NO	included	264	1	-
GE550Y138	3/4"	1,5	NO	YES	YES	included	345	1	-
GE550Y139	1"	2,5	NO	YES	YES	included	411	1	-

Delivery metering units for use in heating and/or cooling circuits.

- Shut-off ball valves
- Depending on the version, there are connections of 3/4" or 1", a motorized zone valve, a static balancing valve and a filter
- Max. working temperature: 110 °C
- Max. working pressure: 16 bar

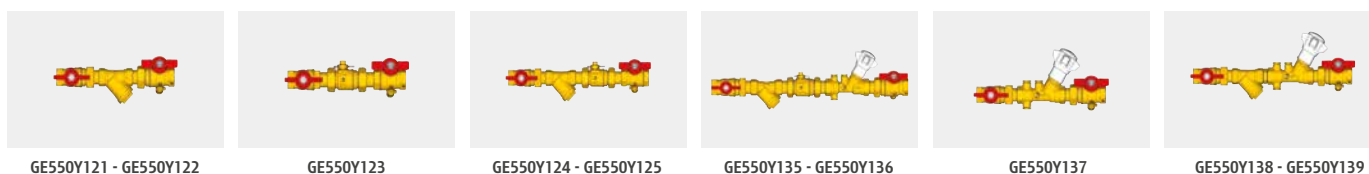

## RETURN UNITS

PRODUCT CODE	CONNECTIONS	NOMINAL FLOW-RATE m <sup>3</sup> /h	PLASTIC SPACER	COLLARS	UNITS LENGHT mm	SPACER CENTRE DISTANCE mm		
GE550Y129	3/4"	1,5	YES	included	254	110	1	-
GE550Y130	1"	2,5	YES	included	300	130	1	-

Return metering units for use in heating and cooling circuits.

- Shut-off ball valves
- Plastic spacer for installation of thermal energy meter
- Max. working temperature: 110 °C (90 °C with plastic spacer)
- Max. working pressure: 16 bar (10 bar with plastic spacer)

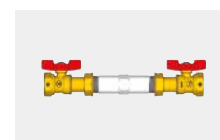

GE550Y129 - GE550Y130

## DELIVERY AND RETURN UNITS

PRODUCT CODE	CONNECTIONS	NOMINAL FLOW-RATE m <sup>3</sup> /h	ZONE VALVES	BALANCING VALVES	COLLARS	UNITS LENGHT mm	SPACER CENTRE DISTANCE mm		
GE550Y166	3/4"	1,5	3 ways	NO	included	422	110	1	-
GE550Y167	1"	2,5	3 ways	NO	included	491	130	1	-
GE550Y168	3/4"	1,5	3 ways	static	included	453	110	1	-
GE550Y169	1"	2,5	3 ways	static	included	491	130	1	-
GE550Y170	3/4"	1,5	3 ways	dynamic	included	444	110	1	-
GE550Y171	1"	2,5	3 ways	dynamic	included	490	130	1	-

Delivery & return metering units, for use in heating and cooling circuits.

- Shut-off ball valves, may be sealed, can be plumbed
- Filter with basket in stainless steel
  - Plastic spacer for installation of thermal energy meter
- Depending on the version, 3/4" and 1" connections, and static or dynamic balancing valves are available
- Max. working temperature: 110 °C (90 °C, with plastic spacer pipe)
- Max. working pressure: 16 bar (10 bar with plastic spacer pipe)



## GE551

### CABINET



Flush-mounting cabinets in painted sheet metal (RAL9010).

- Lockable door
- Adjustable frame depth
- Front and side holes for the system transfer pipes with closure caps
- Box with fairlead for electrical components

PRODUCT CODE	DIMENSIONS (L x H x D) mm	AREAS FOR UNITS FOR HEAT/ COND.	GUIDES FOR DOMESTIC UNITS		
GE551Y031	750 x 1500 x 190	3÷4	3÷4	1	-
GE551Y038	500 x 500 x 110	1	2	1	-
GE551Y039	600 x 600 x 110	1	3	1	-
GE551Y040	600 x 1100 x 110	2	6	1	-

## GE551-1

### FRAMES

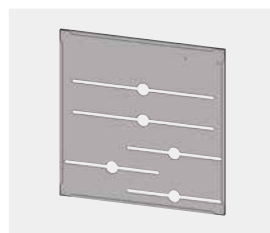

Electro-galvanised metallic frame pre-arranged for the installation of metering units for heating and/or cooling, and units for domestic and/or service water.

PRODUCT CODE	DIMENSIONS (L x H x D) mm	AREAS FOR UNITS FOR HEAT/ COND.	GUIDES FOR DOMESTIC UNITS		
GE551Y154	500 x 500 x 10	1	3	1	-

## GE551-2

### TEMPLATES

#### TEMPLATES FOR STANDARD HIUS, GE556



GE551Y072 EXTERNAL

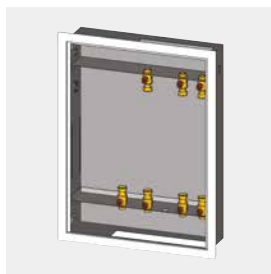

GE551Y073 FLUSH-MOUNTING

Template for installation at the worksite of GE556 HIUs. Completed with shut-off valves.

PRODUCT CODE	CONNECTIONS	DIMENSIONS (L x H x D) mm	NO. OF SHUT-OFF VALVE		
GE551Y072	3/4"	560 x 570 x 165	7	1	-
GE551Y073	3/4"	570 x 770 x 165	7	1	-

#### TEMPLATES FOR HIU WITH ELECTRONIC REGULATION, GE556-2

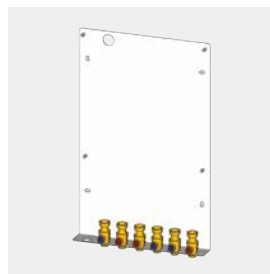

Template for installation at the worksite of GE556-2 HIUs. Completed with shut-off valves.

PRODUCT CODE	CONNECTIONS	DIMENSIONS (L x H x D) mm	NO. OF SHUT-OFF VALVE		
GE551Y074	3/4"	450 x 720 x 72	7	1	-

#### TEMPLATES FOR HIU WITH DIFFERENTIAL PRESSURE CONTROL VALVE, GE556-4



Template for installation at the worksite of GE556-4 HIUs. Completed with shut-off valves.

PRODUCT CODE	CONNECTIONS	DIMENSIONS (L x H x D) mm	NO. OF SHUT-OFF VALVE		
GE551Y075	3/4"	450 x 292 x 72	7	1	-

#### TEMPLATES FOR HIU WITH DOUBLE EXCHANGER, GE556-1

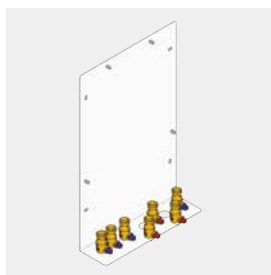

GE551Y081 - GE551Y083



GE551Y082 - GE551Y084

Template for installation at the worksite of GE556-1 HIUs. Completed with shut-off valves.

GE551Y083, GE551Y084: with connection from above (on the back side of the template).

PRODUCT CODE	CONNECTIONS	DIMENSIONS (L x H x D) mm	NO. OF SHUT-OFF VALVE		
GE551Y081	3/4"	450 x 720 x 150	4	1	-
GE551Y082	3/4"	450 x 720 x 150	7	1	-
GE551Y083	Ø22	450 x 720 x 208	4	1	-
GE551Y084	Ø22	450 x 720 x 208	7	1	-

#### TEMPLATES FOR HIU WITH ELECTRONIC REGULATION AND DOUBLE EXCHANGER, GE556-6

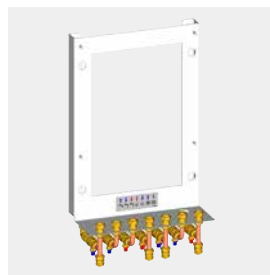

Template for installation at the worksite of GE556-6 HIUs. Completed with shut-off valves.

GE551Y085: with connection from above (on the back side of the template).

GE551Y086: with connection from below.

PRODUCT CODE	CONNECTIONS	DIMENSIONS (L x H x D) mm	NO. OF SHUT-OFF VALVE		
GE551Y085	Ø22	458 x 792 x 218	7	1	-
GE551Y086	3/4"	456 x 60 x 159	7	-	-

## GE551-3

### COLLARS

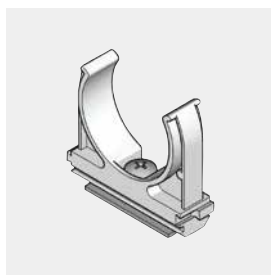

Plastic collars, for fastening metering units for heating and/or cooling and for Domestic and/or service water units.

PRODUCT CODE	DIMENSIONS	USE		
<b>GE551Y002</b>	DN25	For 3/4" outputs	1	-
<b>GE551Y003</b>	DN32	For 3/4" outputs	1	-
<b>GE551Y004</b>	DN40	For 1" outputs	1	-

## GE551-4

### INSULATION



GE551Y171

Insulation for the heating and/or cooling delivery unit GE550Y136.

PRODUCT CODE	DIMENSIONS		
<b>GE551Y171</b>	450 x 250 x 90 mm	1	-



GE551Y179

Insulation for metering units GE550-3 with 70 mm centre distance (codes GE550Y112, GE550Y113, GE550Y114, GE550Y116, GE550Y117, GE550Y144, GE550Y146, GE550Y147).

PRODUCT CODE	DIMENSIONS		
<b>GE551Y179</b>	300 x 110 x 80 mm	1	-



GE551Y173

Insulation for Domestic water meter, GE552-2 series, only for 3/4" sizes.

PRODUCT CODE	DIMENSIONS		
<b>GE551Y173</b>	170 x 90 x 65 mm	1	-



GE551Y180

Insulation for HIUs GE556Y176, GE556Y177.

PRODUCT CODE	DIMENSIONS		
<b>GE551Y180</b>	300 x 430 x 100 mm.	1	-



GE551Y177

Insulation for the GE555Y461 module and heating and/or cooling delivery and return unit GE550Y166.

PRODUCT CODE	DIMENSIONS		
<b>GE551Y177</b>	465 x 125 x 90 mm	1	-



GE551Y182

Insulation for user module GE555Y472.

PRODUCT CODE	DIMENSIONS		
<b>GE551Y182</b>	-	1	-



GE551Y178

Insulation for the GE555Y462, GE555Y463, GE555Y468, GE555Y469 modules and heating and/or cooling delivery units GE550Y167, GE555Y168, GE555Y169, GE555Y170, GE555Y171.

PRODUCT CODE	DIMENSIONS		
<b>GE551Y178</b>	530 x 250 x 90 mm	1	-